

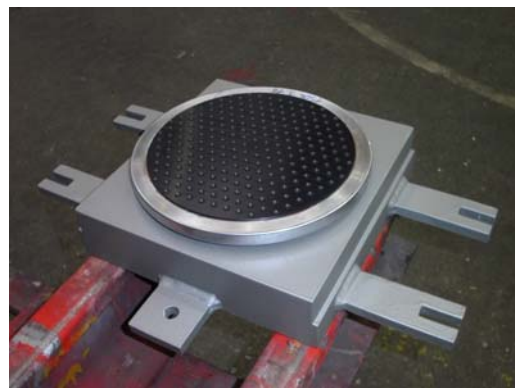

MAURER MSM[®] Sliding Bearings with small longterm wear and therefore ...

- **with low friction resistance,**
- **especially suited for high movement velocities,**
- **for long sliding paths,**
- **for high pressures**
- **and low temperature regions**



1. Introduction

As it can be seen from the specification for guideway bearings for the German "Transrapid" magnetic train, bearings have to comply from case to case with additional conditions that do not apply in usual bridges. Whereas in conventional bridges the bearings are subject to movements in "slow motion", the case is different for High Speed Trains, where the guideway is passed with speeds of up to 500 km/h.

When designing the guideway for the German Transrapid magnetic train, the condition for the sliding material of bearings was the capacity to move as much as 15 mm/s, and yet maintaining long service life of up to 80 years.

Maurer Söhne has accepted the challenge and developed a sliding material named MSM[®] (i.e. MAURER Sliding Material) that even exceeds the requirements set up by the Transrapid Consortium. The new sliding material employs a 40-fold lifetime¹ as compared to the conventionally used

¹ A 40 fold life time holds when linear behaviour between wear and the test parameters can be assumed: Stress 60 N/mm² versus 30 N/mm² (PTFE) makes factor 2; test speed 15 mm/s versus 2 mm/s (PTFE) makes factor 7.5; total sliding path 50 km versus 20 km (PTFE) makes factor 2.5. These 3 factor multiplied result in a total factor close to 40.

sliding material PTFE (TEFLON[®]), and also shows a lower sliding coefficient at lower temperatures. So, whereas on the one hand this newly developed sliding material is ideally suited for high speed railway applications, in addition it is also an ideal sliding material for bearings to be used in suspension bridges and other large steel bridges where relative large movements are induced by live loads in a relatively short time, resulting in a high movement velocity, and over time adding up to a relatively long sliding path.

Another advantage is the design pressure, which is nearly twice as high compared to PTFE. Beside the reduced component dimensions, which are advantageous for the structural design, this also results in reduced product costs.

The required tests to achieve the National Technical Approval were passed successfully. As the performance limits of MSM[®] could not yet be defined, further tests shall be done in the course of a sponsored industry-research project to establish the material properties and to advance MSM[®].

Target of this product information sheet is to give to an interested circle an impression of the performance of the new developed sliding material.



MAURER MSM® Sliding Bearings

*... with small longterm wear and therefore ...
with low friction resistance, especially suited for high movement velocities, for long sliding paths,
for high pressures and low temperature regions*

2. Comparison of newly developed MSM® with conventional PTFE

Tests of the new MSM® material were conducted along the provisions of EN1337-2, which specifies the sliding elements in structural bearings.

All results show clearly the superiority of the MSM® material over PTFE.

2.1 Static Compression Test

Fig. 1 depicts the static compression test of MSM® and compares the performance of MSM® with an earlier made compression test of PTFE.

pict. 1 static compression test with MSM® and PTFE

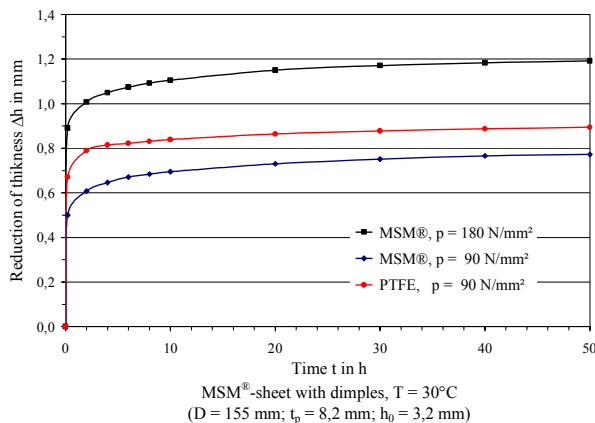

The results of the compression test show that up to a compression of 180 N/mm², MSM® has only limited creeping characteristics. PTFE shows at its belonging characteristic compression f_k = 90 N/mm² (acc. to EN 1337-2) higher values for the long-time creeping.

The reduction of thickness of MSM® is under equal compression values slightly lower than with PTFE. Since for MSM® larger compression values can be reached, obviously the reduction of thickness due to ultimate limit state is bigger than the one of PTFE. This easily can be compensated by using thicker sheets and that way to make sure that the

(compressed) gap height always exceeds the minimum design value.

In like manner the adaption to the deformation of bearing plates due to settlement is achieved.

As a possible consequence and owing to the higher compression strength of MSM®, the base of sliding bearings, especially spherical bearings, could be designed smaller.

2.2 Long-term sliding test for main sliding surfaces

For dimpled MSM® employed in main sliding surfaces, a long-term sliding test was conducted along the provisions of EN1337-2.

However, unlike with PTFE, some parameters were changed, resulting in far tougher test conditions for MSM®.

- Table 1 depicts those parameters that were changed for testing of MSM®.
- Pict. 2 depicts the results of the long-term sliding test at a compression of 30 N/mm². Comparatively, the demanded values acc. to EN 1337-2 (see table 2) for PTFE are displayed. Pict. 2 also depicts the sliding coefficients of MSM® at 60 N/mm², measured in smaller distances. From this follows, that after an initial increase the values remain nearly constant at sliding path. Comparatively, also PTFE-curves are shown.



MAURER MSM® Sliding Bearings

... with small longterm wear and therefore ...
with low friction resistance, especially suited for high movement velocities, for long sliding paths,
for high pressures and low temperature regions

	Dimpled PTFE	MSM®
Contact pressure [N/mm ²] (0,33 f)	30	60
Avg. sliding velocity [mm/sec] and cycle shape	2 sinusoidal	15 constant
Total sliding path of phases 2, 4, 6 [m]	10,000 (20,000) ¹⁾	30,000 (50,000) ²⁾
Sliding path per phase 2, 4, 6 [m]	1,000	1,000 to 11,000

tab. 1: Type B Testing conditions (EN1337-2 Tab. D.3) for phases 2,4,6... (long-term tests)

- 1) The PTFE-standard tests refer to a total sliding path of 10,000 m; some initial tests are available for 20,000 m
- 2) The MSM® long-term test was exceeded from 30,000 m to 50,000 m due to the unexpected good test results.

Temp.	Static friction coefficient μ_x [-]			
	PTFE ↔ Stainless steel (flat sliding surfaces)	PTFE ↔ Stainl. steel / hard chromium (curved sliding surfaces)	PTFE ↔ Aluminium (curved sliding surfaces)	CM1 / CM2 ↔ Stainless steel (in guides)
	Total sliding path [m]			
	10,242	2,066		
-35 °C	0.050	0.030	0.045	0.200
-20 °C	0.040	0.025	0.038	0.150
0 °C	0.025	0.020	0.030	0.100
+21 °C	0.020	0.015	0.022	0.075

tab. 2: Maximum allowable coefficients of friction in long-term sliding tests acc. to EN 1337-2

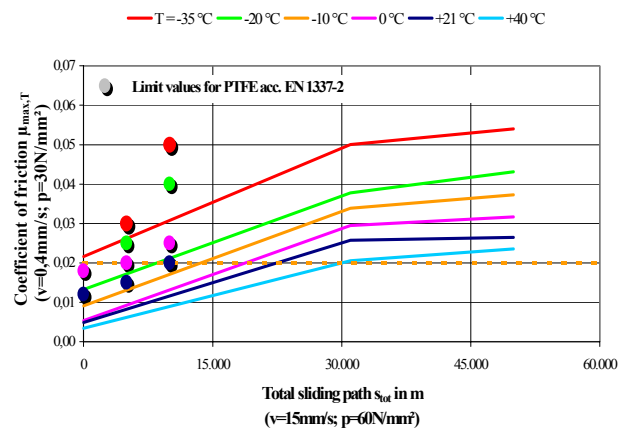

Long term sliding tests of dimpled PTFE and MSM®

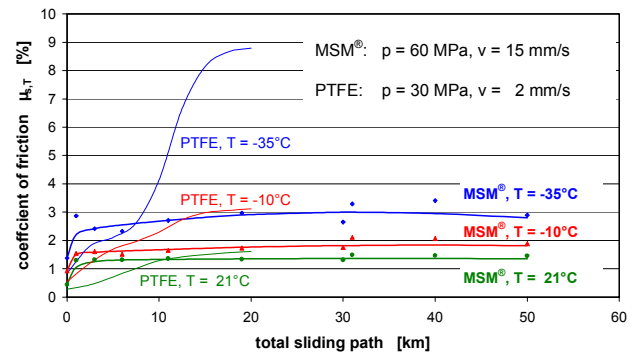

pict. 2: Long-term test of MSM®, as compared to PTFE

It has yet to be emphasized that the comparison between MSM® and PTFE refers to different test conditions (it is worth stating that the ones for MSM® are more unfavourable).

To emphasize the performance of MSM® it shall be noted that PTFE long-term tests with a medium pressure of 45 N/mm² and a sliding velocity of 5 mm/sec already failed completely after achieving 2,000 m sliding path. Consequently, a direct comparison in performance cannot be made when interpreting above pict. 2, but it rather shall provide the reader with an idea of the different performance between the two materials.



MAURER MSM® Sliding Bearings

*... with small longterm wear and therefore ...
with low friction resistance, especially suited for high movement velocities, for long sliding paths,
for high pressures and low temperature regions*

Due to the unexpectedly superior performance of the MSM® (no wear could be observed after 30,000 m total sliding path) it was decided to extend the test to 50,000 m to be able to determine the service life of MSM®. After continuation of this test, it can clearly be seen that the behaviour of MSM® continues to display its excellent performance.

So, even after a sliding path of 50,000 m, no wear could be observed. At this point in time the lifetime of MSM® cannot be specified in terms of maximum sliding path.

Pict. 3 shows the shape of MSM® after a sliding path of 50,000 m and after disassembly of the test specimen. The surplus grease is deposited outside of the sliding area. The sliding material MSM® shows no abrasion which would be noticeable by polluted grease.



pict. 3: shape of MSM® after a sliding path of 50,000 m

Pict. 4 shows the shape of PTFE after a long-term sliding test acc. to EN 1337-2. Although both the stress and the movement velocity were much lower, the wear rate was much higher which can be noticed in the PTFE-particles accumulated in the surplus grease. The wear rate of app. 25 µm per km sliding path means that after app. 60 km, the total PTFE thickness would be worn out and the bearing would lose its functionality. This assumes that despite the abrasion process, the lubricating film is intact for the total sliding path. Non-lubricated PTFE in combination with a $p \times v$ -value of $60 \text{ N/mm}^2 \times \text{mm/s}$ shows a wear rate of up to 750 µm/km . It is safe to assume that after the start of the abrasion process, the PTFE would be worn out after some km of sliding path. Considering the conditions of the MSM®-test for the PTFE, the wear rate could be expected at app. 400 µm/km and accordingly increased coefficients of friction.

After 4 km sliding path at the latest, the sliding element would lose its functionality.

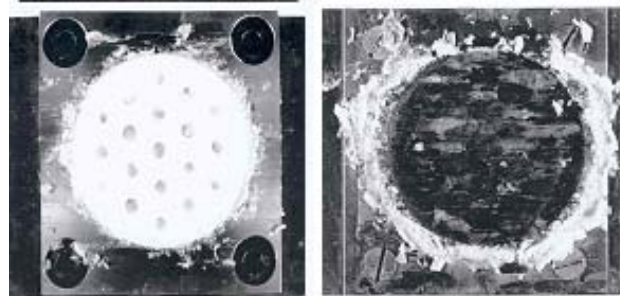

pict. 4: shape of PTFE after a sliding path of 10,000 m

The different abrasion behaviour also is displayed in *pict. 5* where the decrease of the sliding gap, depending on the accumulated sliding path, is displayed. While PTFE shows a nearly constant reduction of the sliding gap, the MSM® sliding gap stays nearly constant after the initial settlement – despite the more unfavourable test parameters. This is a further indication that in case of MSM® the abrasion process has not yet started after completion of the tests and the performance limits are not yet reached.

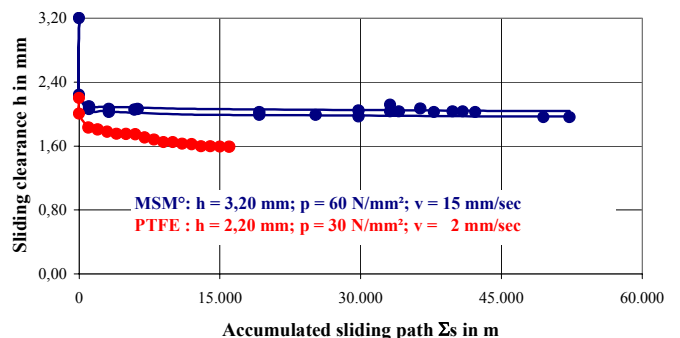

pict. 5: abrasion values for MSM® and PTFE



MAURER MSM® Sliding Bearings

... with small longterm wear and therefore ...

with low friction resistance, especially suited for high movement velocities, for long sliding paths, for high pressures and low temperature regions

2.3 Friction coefficients following EN 1337-Part 2 for the sliding material MSM® in main sliding surfaces

The coefficient of friction was tested during the long term sliding test (pict. 2). Despite the higher strains (7,5 times velocity, 2 times compression), the coefficients of friction for MSM® were much lower than the ones for PTFE at the same accumulated sliding paths (acc. to EN 1337-2).

Only after 5 times the PTFE-sliding path for the MSM® specimen, the same coefficient of friction as for PTFE occurs. The European standard for sliding elements EN 1337-2 does not define the required performance of sliding materials, but it describes the testing procedures and the required results to identify the prescribed sliding material. That's why a specific test result does not allow to draw direct conclusions for the design values of an alternative sliding material. Additional comparing investigations are necessary.

The following reflections help to define the MSM® friction coefficients for different operative ranges and under the following assumptions:

- EN 1337-2 defines –within the validity area and independent from the general conditions (i.e. temperature, sliding path and –velocity)– the friction values for PTFE for the design of bearings following the equation:

$$0.08 \geq \mu = \frac{1.2}{10 + p[N/mm^2]} \geq 0.03$$

Above the mean pressure $p = 30 \text{ N/mm}^2$ (i.e. maximum characteristic pressure, resulting from permanent load), the friction coefficient $\mu = 0.03$.

- The friction values for MSM® after achieving 50,000 m sliding path (determined at $p = 30 \text{ N/mm}^2$ and $v = 0.4 \text{ mm/sec}$) correspond approximately to the PTFE-friction values after achieving 10,000 m sliding path – even though the long-term tests differ in the following parameters:

	PTFE	MSM®
Pressure [N/mm ²]	30	60
Velocity [mm/sec]	2	15
Speed cycle mode	sinusoidal	Constant

tab. 3: testing parameters

The tests resulted for both PTFE and MSM® in a friction value of app. 5 % (at $T = -35^\circ\text{C}$ and $p = 30 \text{ N/mm}^2$). According to EN 1990, $T_1 = -10^\circ\text{C}$ can be defined as “frequent value of low temperature”. Following the standard, the “frequent value” T_1 shows a 5 %-probability of being exceeded during service life, while the “characteristic value” T_k will be reached only once in 50 years. Likewise, a “frequent value of friction” $\mu_1 = 3 \%$ can be calculated following the equation $\mu_1 = \psi_1 \cdot \mu_k$, where $\psi_1 = 0.6$ is the combination factor and $\mu_k = 5 \%$ is the characteristic friction at the characteristic temperature $T_k = -35^\circ\text{C}$.

- Based on the same sliding path, MSM® shows much better friction values than PTFE – although the test parameters are intensified ($\mu_{\text{MSM}^\circ} < 0.70 \mu_{\text{PTFE}}$).

Considering these results, the following approaches can be displayed:

1st approach

The compression-depending friction value is defined by means of sliding tests at the “frequent value of low temperature” $T_1 = -10^\circ\text{C}$ and for the maximum sliding path (50,000 m for MSM®). The friction value is limited to the resp. value for the employed compression during the long term sliding test (for MSM®: 60 N/mm^2).

The following relation is valid (see pict. 6):

$$0.08 \geq \mu = \frac{1.6}{15 + p[N/mm^2]} \geq 0.02$$





MAURER MSM® Sliding Bearings

... with small longterm wear and therefore ...
with low friction resistance, especially suited for high movement velocities, for long sliding paths,
for high pressures and low temperature regions

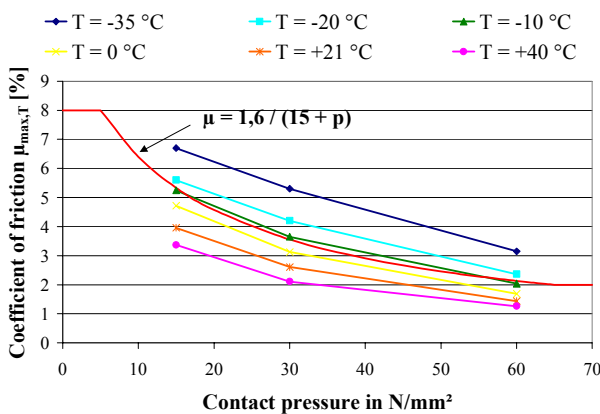

pict.6: pressure-depending friction values for MSM® (1st approach)

2nd approach

The 2nd approach additionally considers the sliding path. Being on the safe side (v=15 mm/sec instead of 2 mm/sec, constant cycle mode instead of sinusoidal), the friction coefficient shall be reduced in the ratio of the friction coefficients for 10,000 m. This rule shall be valid for standard cases, where the application of PTFE also would be possible:

$$\frac{\mu_{MSM}}{\mu_{PTFE}} [T_1 = -10^\circ C, s = 10,000m] = \frac{0.175}{0.250} = \frac{7}{10}$$

$$\rightarrow 0.055 \geq \mu_{MSM} = \frac{1.1}{15 + p [N / mm^2]} \geq 0.015$$

3rd approach

The 3rd approach also considers the design temperature (e.g. the "frequent value of low temperature" T₁ according to EN 1990) and the fact that at T= -35°C the friction coefficient is 5/3 times the T=-10°C-value:

$$\mu_T = \frac{1.1}{15 + p [N / mm^2]} \times \left(\frac{210}{220 + T_1 [^\circ C]} \right)^4$$

In case of T₁ = -35°C, T_k = -60°C and the application of MSM® instead of PTFE, the friction coefficient would be

$$0.092 \geq \mu = \frac{1.83}{15 + p [N / mm^2]} \geq 0.025$$

Despite the lower temperatures, the coefficient of friction for MSM® (2.5%) will be less than the coefficient of friction for PTFE (3%) due to the higher design value for compression (60 N/mm² instead of 30 N/mm²).

The statement in EN 1337-2 to reduce the friction coefficients with the factor 2/3 in case of T_k > -5°C requires a temperature T₁ = 10°C.

In conclusion, it can be stated that the application of MSM® instead of PTFE guarantees a maximum friction coefficient of 3% - also in case of very low temperatures, combined with high movement velocities and long sliding paths. In case of using MSM® under "PTFE-conditions", the friction value is considerably lower.

2.4 MSM® in guides

Analogous to the main sliding surfaces, long term sliding tests following EN 1337-2 were done at MSM®-strips with initial lubrication. The sliding velocity again was constantly 15 mm/sec (instead of sinusoidal 2 mm/sec for PTFE). The accumulated sliding path again was considered with the factor "5", i.e. 10,000 m instead of 2,000 m. The compression again was 60 N/mm² instead of 30 N/mm².

The excellent characteristics of MSM® are proven. *Pict. 7* displays (analogous to *pict. 2*) the test results as well as the demanded values for PTFE-strips. The shape of the MSM®-strips after the long term sliding test is shown in *pict. 8*. At the end of the test, a coefficient of friction μ = 0.096 appeared at a frequent value of low temperature T₁ = -10°C and a compression of 30 N/mm². For PTFE and the belonging sliding path of 2,000 m, the coefficient of friction is μ = 0.047.



MAURER MSM® Sliding Bearings

... with small longterm wear and therefore ...
with low friction resistance, especially suited for high movement velocities, for long sliding paths,
for high pressures and low temperature regions

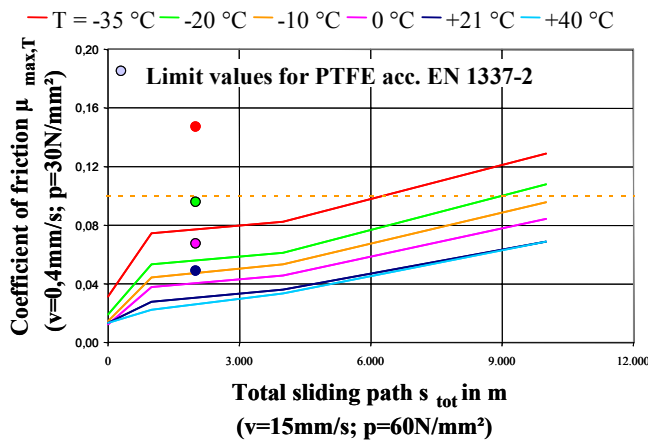

pict. 7: long-term sliding test at MSM®-strips

Following EN 1337-2, for PTFE a coefficient of value $\mu = 0.08$ is achieved which is used for the design calculation and independently from the existing pressure.



pict. 8: MSM®-strips after a sliding path of 10,000 m

Considering the same approaches as for the main sliding surfaces, the following design values turn out:

1. $T_1 = -10^\circ\text{C}$, $\Sigma s = 10,000 \text{ m}$
 $\mu_d = 0.10$
2. $T_1 = -10^\circ\text{C}$, $\Sigma s = 2,000 \text{ m}$
 $\mu_d = 0.05$ (comparative to: $\mu_d = 0.08$ for PTFE)
3. $T_1 = -35^\circ\text{C}$, $\Sigma s = 2,000 \text{ m}$
 $\mu_d = 0.077 \approx 0.08$

2.5 Further tests

Also conducted were

- short-term compression tests for the determination of the permissible stresses
- short-term compression tests for the determination of the strain
- short-term compression tests for the determination of the performance under eccentric loads.
- a long-term static test to determine the strain under long term conditions
- a short-term test for the determination of the friction coefficient as a function of loads and accumulated sliding path

All these tests that were conducted along the provisions of EN1337-2 proved the superior performance of MSM®.

3. National Technical Approval Z-16.4-436

As already mentioned in chapt. 2, the code EN 1337-2 only deals with sliding elements equipped with PTFE. For the use of MSM® in structures subject to a national site supervision, the EN code has to be amended or alternatively, a National Technical Approval is required.

That's why for the unimpeded use of MSM® in Europe, an application for granting a European Technical Approval (ETA, file-no.: 8.03.01-0005/03) was submitted at the European Organization for Technical Approvals (EOTA). Considering the expected processing time of several years, it was applied for a German National Technical Approval for MAURER-MSM®-Spherical Bearings in advance. This approval was granted by the German Institute for Structural Engineering (Deutsches Institut für Bautechnik) under the approval-no. Z-16.4-436. As the codes in force (EN 1337-2) do not restrict the use of PTFE according to the occurring load- and movement values, also the MSM®-approval does NOT define a quantitative coherence between structural requirements (on the load side) and tolerable movement velocities or sliding paths proven by tests (on the material side).



MAURER MSM® Sliding Bearings

*... with small longterm wear and therefore ...
with low friction resistance, especially suited for high movement velocities, for long sliding paths,
for high pressures and low temperature regions*

However, the following qualitative statements are given:

„1 Subject of Approval and field of application

... MAURER- MSM®-spherical bearings are particularly suitable for soft structures with relatively large and frequent displacements caused by traffic, next for structures that employ fast sliding displacements of the bearings, like in bridges for high speed railways, as well as for regions of continuously low temperatures...“

„2.1.1.1 MSM®

... In respect to the durability, long-term sliding tests (see DIN EN 1337-2:2001, section D 6.2) were conducted with a total sliding distance of 50,000 m, a sliding velocity of 15 mm/sec, and a contact pressure of 60 N/mm², as also long-term compression tests were conducted with a contact pressure of up to 200 N/mm². These tests showed that no remarkable wear and increase of the friction coefficients occurred, and the creep effect was greatly completed after 48 hours.“

What specifically is stated is the value for the characteristic compressive strength f_k as well as the coefficient of friction μ , which is depending on the compression value:

$$0.08 \geq \mu = \frac{1.6}{15 + p[N/mm^2]} \geq 0.02$$

tab. 4: Values for the characteristic compressive strength of sliding surfaces

		MSM®	PTFE	CM1
Characteristic compression strength f_k [N/mm]		Main sliding surface Dead loads and variable loads		200
			180	
	Guides	Variable loads		200
			60	
	Effects of temperature, shrinkage and creep			
	Dead loads		10	
Partial safety coefficient $\gamma_m = 1.4$				

As a consequence, MSM®-elements can be designed acc. to the Technical Approval (and despite the more severe test conditions compared to PTFE) with, as a rule, double compression values. Furthermore, the coefficient of friction can be considered with e.g. 2 % instead of 3 % in case of German climate conditions.

Additionally, the geometrical boundary conditions were lifted in favour of the bridge bearing durability. Sliding gap heights $h > 1$ mm indicate a “regular” condition of a sliding bearing. Increasing the design value for h therefore means also increasing the safety against the limiting value $h=0$. On the other hand, a deeper recessing of the sliding material also reduces the yield tendency. Tab. 5 displays the threshold values for MSM® and PTFE.



Nr. 39a-gb
VBA / GB
08/2003
9 / 14

MAURER MSM® Sliding Bearings

*... with small longterm wear and therefore ...
with low friction resistance, especially suited for high movement velocities, for long sliding paths,
for high pressures and low temperature regions*

	MSM®	PTFE
Sliding gap height h [mm]	$h = 2.50 + \frac{L}{3,000}$	$h = 1.75 + \frac{L}{1,200}$ $h_{min} = 2.2mm$
Thickness t _p [mm]	$2.65h \leq t_p \leq 10mm$	$2.20h \leq t_p \leq 8mm$
L ... diameter of sliding plate [mm]		

tab. 5: Sliding gap heights and plate thickness

While for PTFE the plate thickness varies between 5 and 7 mm (depending on the sliding plate diameter), the thickness for MSM® nearly constantly is 8 mm. As for instance for L = 600 mm, the sliding gap height for MSM® is 2.7 mm, for PTFE 2.25 mm. The recessing depth has to be considered for MSM® with 1.65 times the sliding gap height instead 1.2 times in case of PTFE.

As for PTFE sliding bearings, the field of application for MSM® sliding bearings is restricted to a max. L = 1,500 mm. Due to the high characteristic compression values of MSM®, design loads up to app. 200 MN can be covered (according to the fundamental load combination in ULS case as specified in EN 1990) and app. 150 MN can be covered acc. to the presently valid global safety conception. That way, the biggest sliding bearings ever installed are included in the codes - so far a specific approval was required for this bearing size. Additionally it can be emphasized that MSM® can be produced without splice up to a diameter of 2,000 mm (i.e. design load = 365 MN), while PTFE-sheets only are available without splice up to a diameter of 1,300 mm (i.e. design load = 77 MN).

The production of MAURER-MSM®-spherical bearings according to the National Technical Approval is supervised by the MPA Stuttgart as third-party-control institution. While the so-called "system 1" for attestation of conformity acc. to EN 1337-2, annex ZA ("CE-sign"), only considers the check of the in-house supervision, the National Technical Approval also demands a third-party-control of the production ("Ü-sign").

The Austrian Department of Trade and Industry already has agreed to the use of MAURER-MSM®-spherical bearings according to the existing German National Technical Approval until the European approval is issued. Furthermore, applications are issued for National Technical Approvals in several other countries.

4. Classification of structures

Due to traffic, at the supports mainly rotations α_i are created due to the deflection of the superstructure. As a consequence, in case of spherical bearings a sliding movement w_α is created in the curved sliding surface (radius R_k), in case of pot bearings a vertical sliding of the inner sealing element along the wall of the pot (with a diameter of the elastomeric pad D_p) is caused. In both cases, according to EN 1337 an accumulated sliding displacement to be tested in the laboratory of a maximum of 2,000m is required as a proof of suitability.

$$w_\alpha = R_k \times \alpha_i$$

Depending on the distance to the centre of gravity h_s , the rotation α_i results also in a displacement w_i . That way, the displacement w_F of the total structure as a function of nature and location of the fix point as well as the structural system has to be considered.

$$w_i = h_s \times \alpha_i + w_F$$

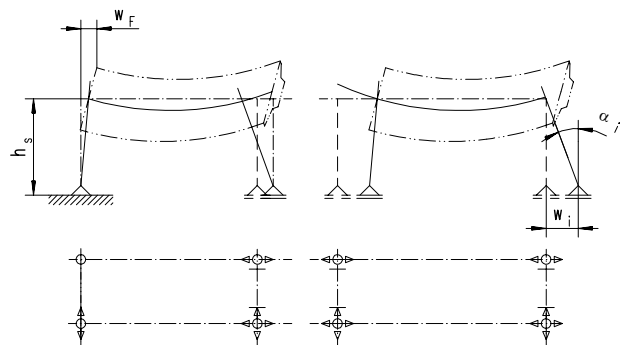

pict. 9: support displacements due to live loads



MAURER MSM® Sliding Bearings

*... with small longterm wear and therefore ...
with low friction resistance, especially suited for high movement velocities, for long sliding paths,
for high pressures and low temperature regions*

Each passing of a vehicle results in an accumulated rotational angle $\Delta\alpha_i$, and as a function of the vehicle velocity a displacement period t_i as well as an average velocity v_i ,

$$\Delta\alpha_i = 2 \times [\alpha_i(+)+\alpha_i(-)]; \quad v_i = \frac{2 \times [w_i(+)+w_i(-)]}{t_i}$$

Depending on the composition of the live load, it comes to an accumulated sliding displacement Σw_i over the service life. Table 6 displays the parameters for selected special cases in comparison to the stipulations of EN1337.

Structure	Accum. Sliding path Σw_i [m/year]	Avg. velocity $v_{i,av}$ [mm/sec]	Amplitude w_i [mm]
Transrapid ¹⁾	625	15	7
Rio Tejo Bridge 25. Abril / Lisbon ²⁾	10,000	15 to 20	150
Suspension Railway Wuppertal ³⁾	7,000	30	45

¹⁾ Specification values for the Transrapid track Hamburg-Berlin (for the 12° curved girder)
Design parameters: 14.4 Mio. Passgrs./year, 80 trains/day, 450 km/h Maximum speed
²⁾ Combined Road-/Rail-Suspension Bridge with spans 483 m – 1,013 m – 483 m, train passing each 7.5 min., 140 trains per day
³⁾ app. 175,000 crossings per year

tab. 6: design parameters for sliding bearings of selected projects

For the determination of the long-term characteristics of a bridge bearing, it is not the magnitude of the individual movement that plays a decisive role, but the accumulated rotations and displacements that arise during the lifetime of a bridge bearing. In this respect the displacement of the structure due to temperature, creep and shrinkage only plays a minor role. Of deciding relevance are displacements and the displacement velocities due to live loads. In order to determine the total accumulated design displacement S_d of the sliding surfaces of rotational elements, the live load models according to EN1991 can be taken into account. It holds:

$$S_d = \sum n_v \times \Delta\alpha_i \times \frac{D}{2} \leq c \times S_T$$

n_v is the number of the occurring rotational differences due to live loads, S_T holds for the experimentally proven sliding displacement that can be accommodated.

The conversion factor “c” serves for the consideration of the “real life” variable amplitudes. For road bridges, a factor “5” and for railway bridges, a factor “1” is considered to be plausible.

In respect to the suitability of sliding bearings, structures have to be distinguished according to their mode of usage (road bridge, railway bridge), the material employed (reinforced concrete, prestressed concrete, steel, composite) as well as their static system (single girder or continuous girder, arch bridge, cable stayed bridge, suspension bridge). For each mode of combination and depending on the span width and the distribution of traffic loads, there will be an accumulated sliding displacement and an accumulated rotational angle which can be used for further judgment. For instance in pict. 10 and 11, for a number of small- and medium sized bridge spans width and for various modes of usage and construction modes, the maximum rotational differences $\Delta\alpha_i$ as well as the sliding displacement per passing is displayed. Thereby, for the design of railway bridges the design load UIC 71 and for road bridges 60% of the design load truck SLW 60 (60 tons) of DIN 1072 is considered. These design loads roughly correspond to the fatigue design model 3 of EN 1991-2. In both cases thus the design loads relevant for fatigue design are employed.



Nr. 39a-gb
VBA / GB
08/2003
11 / 14

MAURER MSM® Sliding Bearings

**... with small longterm wear and therefore ...
with low friction resistance, especially suited for high movement velocities, for long sliding paths,
for high pressures and low temperature regions**

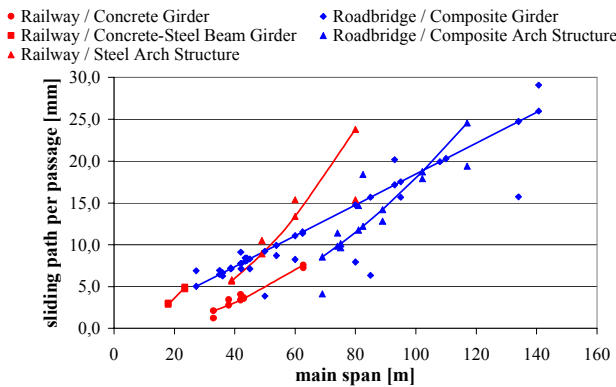

pict. 10: support displacements due to traffic loads

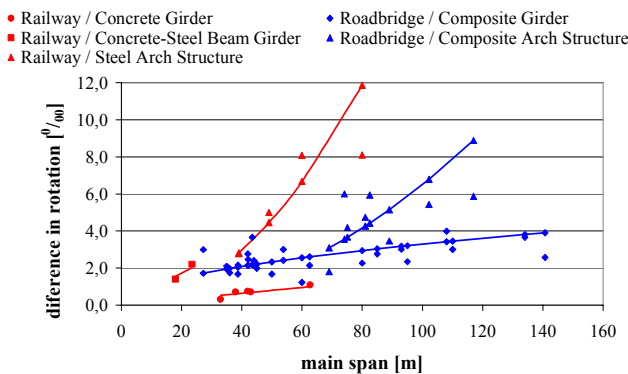

pict. 11: support rotations due to traffic loads

A bridge of a span width of 100 m thus displays -due to traffic service loads- an accumulated sliding displacement per passing of app. 20 mm. In case of road bridges and 5*10⁵ crossings per year (traffic category 2 according to EN 1991-2), not considering additional influences from other traffic lanes, this corresponds to an accumulated sliding displacement of 10 km. Assuming the related rotational difference to be 5 ‰, and considering e.g. a radius R of the sliding plane to be 500 mm, the resulting sliding displacement due to rotation calculates to 2.5 km. In case of railway bridges and 7.5*10⁴ crossings per year (standard mixed traffic according to EN 1991-2), a span width of 75 m,

and a sliding displacement of 25 mm per passing, this corresponds to an accumulated sliding displacement of 2.0 km. Assuming the related rotational difference to be 10 ‰, and considering e.g. a radius R of the sliding plane to be 500 mm, the resulting sliding displacement due to rotation calculates to 0.5 km.

EN 1337-2 exclusively regulates the use of PTFE. A definition of performance characteristics is not yet done. The examples and investigations shown provide a first general idea of the possibility to classify structures according to mode of usage, material, mode of construction and span width. A systematic and scientific elaboration of the topic and its integration into the standards is required.

5. Structural dimensions

Due to the high characteristic compression values of MSM®, the bridge bearing dimensions are mainly determined by the load capacity of the adjacent structural members, assuming that the allowable stress in the connecting gap does not exceed the characteristic compression value of MSM® - but this only might occur in case of extremely stiffened steel superstructures.

The connection to adjacent concrete members is designed by means of the proof of partial area pressure for the fundamental load combination according to EN 1990, see pict. 12.

$$V_d = A_{c0} \times f_{cd} \times \sqrt{\frac{A_{c1}}{A_{c0}}} \leq 3,0 \times A_{c0} \times f_{cd}$$

$$f_{cd} = \alpha \times \frac{f_{ck}}{\gamma_c} = 0,85 \times \frac{f_{ck}}{1,5}$$



MAURER MSM® Sliding Bearings

... with small longterm wear and therefore ...
with low friction resistance, especially suited for high movement velocities, for long sliding paths,
for high pressures and low temperature regions

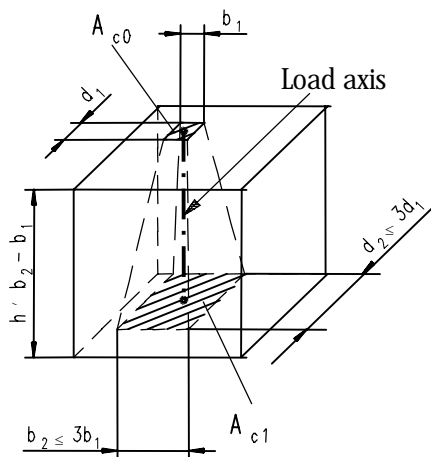

pic. 12: Proof of partial surface compression

As for instance in Germany the case is as follows:
The minimum required strength of a concrete C 35/45 is $f_{cd} = 19,8 \text{ N/mm}^2$ and $V_{d,max} [\text{N}] = 59,5 \cdot A_{c0} [\text{mm}]$.
The main dimensions of a MAURER-MSM® spherical bearing, type KGa acc. to pict. 13 can be calculated (considering 10 % surplus for eccentricity resulting from friction and rotation) as follows:

$$L_u = B_u [\text{mm}] = c \times \sqrt{V_d [\text{MN}]}$$

C35/45...c = 135

C40/50...c = 125

The dimensions of the sliding plates are depending on the values of the movement capacity e_x (+/-):

$$B_{GL} = B_u + 40\text{mm}; \quad L_{GL} = L_u + 2 \times e_x + 80\text{mm}$$

The height of the bearing body can be estimated as follows:

$$H = 3 \times V_d [\text{MN}] + 100\text{mm}$$

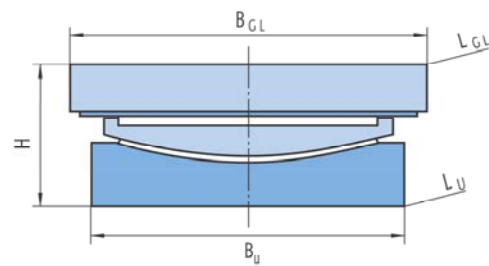

- H
- L_u = B_u
- B_{GL}
- L_{GL} (ex=+/- 50mm)
- L_{GL} (ex=+/- 100mm)
- L_{GL}

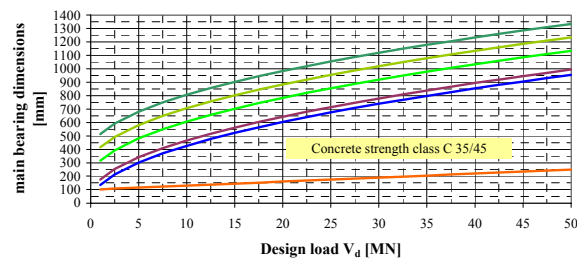

pic. 13 main dimensions of MAURER-MSM®-spherical bearings, type KGa

These values are not binding and have to be calculated for every specific case – but the main dimensions for a free sliding spherical bearing can be calculated roughly by means of the mentioned formulas. For unidirectional moveable KGa or for fixed KF bearings, the dimensions depend on the size of the horizontal forces that have to be transmitted. These bearings will be bigger but in the same scale.



MAURER MSM® Sliding Bearings

... with small longterm wear and therefore ...

with low friction resistance, especially suited for high movement velocities, for long sliding paths, for high pressures and low temperature regions

6. Summary

In comparison to PTFE, MSM® employs the following strengths:

- High compression strength: can accommodate double as much stress, which results in smaller dimensions, reducing manufacturing costs
- High movement velocity (factor 7.5 tested)
- High sliding path (factor 2.5 tested, with no apparent upper limit)
- Low friction
- Low Temperature
- Long service life reduces maintenance costs

7. Conclusion

First comprehensive tests show that MSM® serves as an ideal sliding component that is subject to fast movements or long sliding paths, like in high speed railway bridges or suspension bridges.

MSM® is the preferred choice in those areas where the use of conventional PTFE sheets will not comply to the required performance, like for example at very low temperatures.

Even in conventional applications (e.g. spherical bearings) the use of MSM® would reduce the size of the bearing if feasible (i.e. if the substructure can transfer the higher stresses that stem from the higher design pressure of MSM®).





Nr. 39a-gb
VBA / GB
08/2003
14 / 14

MAURER MSM[®] Sliding Bearings

*... with small longterm wear and therefore ...
with low friction resistance, especially suited for high movement velocities, for long sliding paths,
for high pressures and low temperature regions*

Reference Projects:

- Allianz Arena Munich
- Subway Moscow
- Tejo-Bridge Lisbon/Portugal
- Incremental shifting bearings, Viaduc de Millau
- Suspension Railway Wuppertal
- Transrapid-Testing course Lathen
- Channel Bridge Schwarzach
- „Sarcophagus“ Tschernobyl
- TGV France
- AVE Spain

