

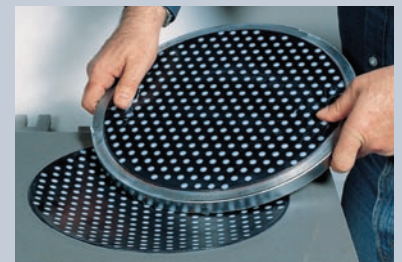

# MAURER MSM<sup>®</sup> Sliding Bearings

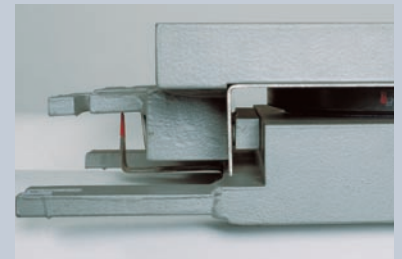

**MAURER MSM<sup>®</sup> – the Innovative Sliding Material**

## What is MSM®?

MSM® is an innovative and patented sliding material for bridge sliding bearings. MSM® is also suitable for other applications, such as incremental launching bearings, earth quake devices, or sliding bearings in buildings.

MSM® is a modified polyethylene, featuring enhanced sliding characteristics and an increased load bearing capacity by means of blending with various additives.

MSM® contains no regenerated or filling material.

MSM® is a thermoplastic resin, insensitive against chemical loading and ageing, without environmentally hazardous components, e.g. like fluorine or chlorine.

MSM® stands for MAURER Sliding Material. The name is a registered brand name.

MSM® is exclusively produced for Maurer Söhne.

MSM® Sliding Bearings can be designed at half the size compared to the dimensions of conventional bearings with PTFE. Like PTFE (white), MSM®-sheets (black) are recessed into a backing plate by about half of their thickness.

The lubrication is effected by means of dimples filled with standard silicon grease.



## Material Characteristics

MSM® is particularly suited for high speed motions. [In comparison to PTFE, it displays less wear at a 7.5-fold displacement speed.]

MSM® can take high loads. [In comparison to PTFE double contact pressure.]

MSM® is suitable to be used under high temperature conditions up to 70°C [PTFE only up to 48°C – with decreasing load-bearing capacity at temperatures exceeding 30°C].

MSM® causes little friction. At temperatures down to -35°C, the coefficient of friction is 2% [PTFE 3%].

MSM® can be used down to temperatures of -50°C with a coefficient of friction below 3% [PTFE cannot be used below -35°C].

MSM® reaches a very long service life. [5-fold accumulated sliding displacement as compared to PTFE, without visible signs of wear.]

MSM® can accommodate subsidence cavities and evenness deviations due to its elasto-plastic behaviour [rigid sliding materials may lead to local overstrain and wear].

The development of MSM® was initiated during the execution of tests for Maglev-Train tracks. In the early stages, the demand was to design a bridge bearing which is capable to withstand high movement velocities and which offers a long service life period. In the end, MSM® represents a new sliding material which offers superior performance in all relevant characteristics [compared to conventionally used PTFE].

MSM® can display the total band width of its superior material characteristics in the spherical bearing, allowing a more economic manufacture as compared to (necessarily larger) pot sliding bearings or elastomeric sliding bearings.



MSM® is also suitable in lateral guides of sliding bearings.

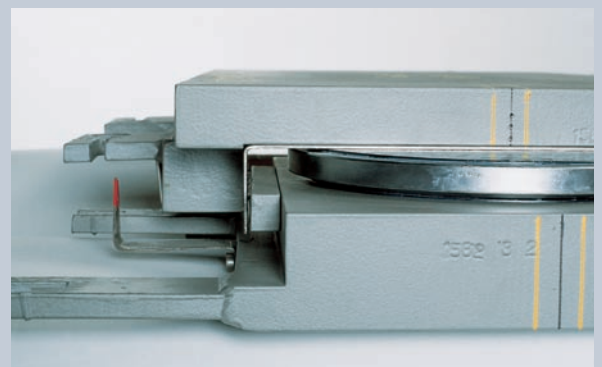

# What can MSM® achieve?

MSM® employs enormous economising potential and new possibilities in bridge construction.

## ■ Unmatched at high performance requirements

At extreme strains (e.g. high speed motions, high contact pressures, high accumulated sliding displacements, very high and very low temperatures), MSM® is the only sliding material that matches all performance requirements. Thus, MSM® fills a gap in particular for high speed railway bridges, soft structures and bridges with high traffic loads or long span widths.

## ■ Smaller dimensions

Due to the doubled design contact pressure of MSM® against PTFE, MSM® Spherical Bearings can be dimensioned half the size of bearings with PTFE.

## ■ Spherical Bearings instead of Pot Bearings

As the MSM® Spherical Bearings can be designed smaller compared to (necessarily larger) pot sliding bearings or sliding elastomeric bearings, in many cases it is also more economical.

## ■ More economical construction method

The smaller dimensions facilitate more slender and thus more economical constructions due to enormous savings in material.

## ■ 40-fold increased service life

Considering all material characteristics and advantages, compared to PTFE MSM® employs a minimum 40-fold increased life time. This leads to considerably reduced maintenance costs, and thus in long run to enormous cost savings. As a rule, the service life of MSM® spherical bearings achieves min. 50 years. That means that usually required auxiliary facilities (e.g. jacking-up areas) can be abandoned. In combination with smaller bearing dimensions, investment costs can be reduced – while the architectural degrees of freedom increase.

**Conclusion:** Compared to PTFE, the new sliding material MSM® displays many advantages – and even if the superior performance characteristics are not considered, MSM® is neutral with respect to costs.

REFER, E.P.



Tejo Bridge „25th April“, Lisbon/Portugal:  
MSM® Spherical Bearings for 10 km sliding path/year  
at 15 mm/s

Horst-Peter Krause



Suspended Monorail at Wuppertal/Germany: Test of  
MSM®-elements for 7 km sliding path/year at 30 mm/s

Eiffage TP



Viaduct de Millau/France: Incremental launching system,  
64 synchronically controlled MSM® shifting devices

ALLIANZ Arena München Stadion GmbH



Allianz Arena,  
Munich/Germany:  
MSM® Spherical  
Bearings to support  
the roof structure

## References

Due to the high performance requirements which are met by MSM®, it is employed in the following projects (examples):

- New Acropolis Museum, Athens
- Allianz Arena, Munich
- High Speed Railways  
AVE in Spain  
TGV in France
- Metro Moscow
- Incremental Launching Bearings,  
Viaduc de Millau
- Rügen Bridge, Stralsund
- "Sarkophagus" Chernobyl
- Suspended Monorail, Wuppertal
- Svinesund-Bridge, Norway/Sweden
- Tejo-Bridge Lisbon
- Transrapid (Maglev) test track,  
Lathen
- Tsing Ma Bridge, Hong Kong
- Viaduct Enzenstetten, Füssen

## MSM® at test

In respect to its material characteristics, MSM® was thoroughly tested at the National Material Testing Institute of the Stuttgart University of Technology (MPA). The test arrangement was identical as it is required for friction tests according to EN 1337 for the qualification of components for structural bearings. So far, the long term tests did not generate any signs of wear. The data displayed on these 2 pages thus describe the performance within the test range. The limits of MSM® could however not yet be reached.

To cite the conclusion of MPA Stuttgart: "To summarize, it can be noted that, based on the regulations for the use of white PTFE to be used as component in structural bearings, no reservations can be made for the use of the Maurer Sliding Material MSM®. In addition, MSM® can cover performance requirements in areas where PTFE has obviously failed and that therefore are not considered in the regulations. Even under relatively high strain (contact pressure  $p$  to a maximum of  $200 \text{ N/mm}^2$  - static load, respectively  $60 \text{ N/mm}^2$  - dynamic load, speed  $v$  up to  $15 \text{ mm/s}$ ), only limited deformations due to creep and relatively low coefficients of friction can be noted. Further, practically no signs of wear or other relevant damages could be detected in the contact area."

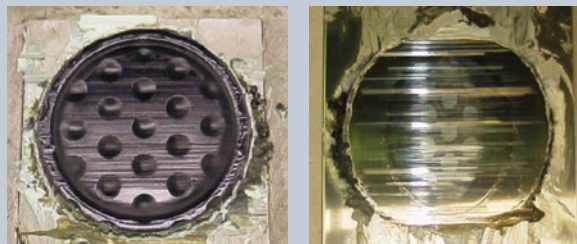

Photos of an MSM®-sheet (left) and a stainless steel sheet (right), taken after opening the test bearing and after completion of the 50 km test. Little scars can be found (also at the bottom of the dimples), but no wear.

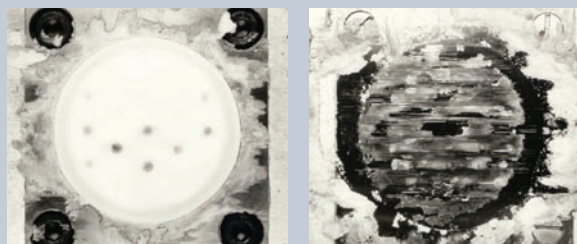

In contrast to this, the photos of the PTFE clearly show abrasion of the material. These photos were taken also at the MPA Stuttgart, after completion of the 10-km-long term test according to EN 1337-2.

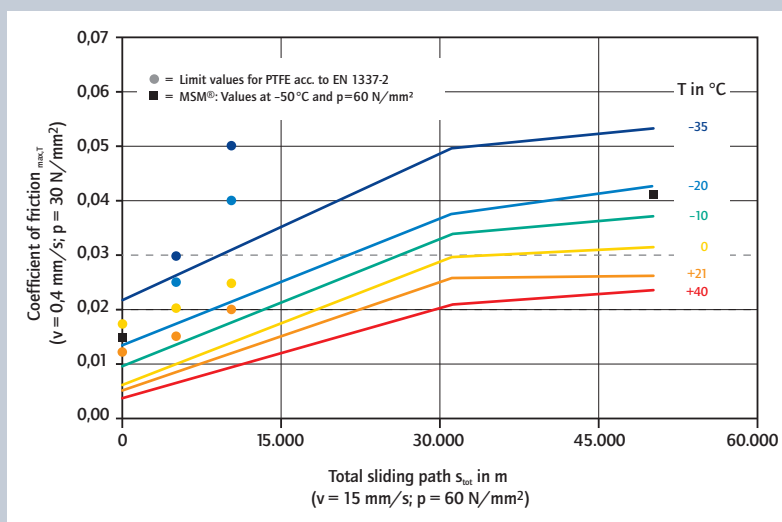
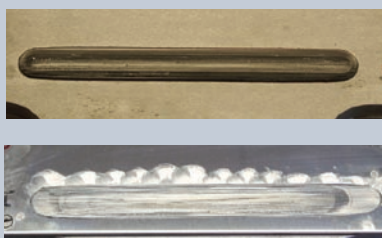

Figure A: MSM®-sheets in long term sliding test (with dimples)



After completing the 10 km test at the MPA Stuttgart, it can clearly be noted that the MSM®-strips and the stainless steel sheet show no signs of abrasion.

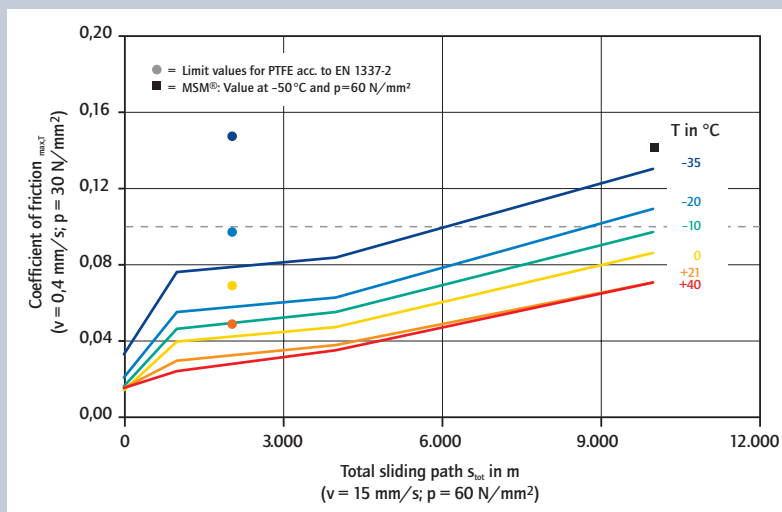
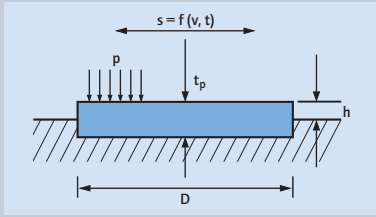

Figure B: MSM®-strips in long term sliding test (without dimples)



The conducted tests comprised long and short term tests under static load as well as sliding tests. In all tests, the constant components (i.e. mating partners) to be applied in the test bearings were the stainless steel sheet and silicon grease in bridge bearing quality.

**Figure A**

Testing subject were MSM®-sheets exposed to a long term sliding test. Figure A shows that the coefficient of friction of MSM® remains under the relevant limits of PTFE, which are defined in EN 1337-2. Even after an accumulated sliding displacement of 50 km, MSM® exceeds the relevant value of PTFE (after 10 km) only to a very small degree. In this test, the accumulated sliding displacement was executed at room temperature and an average contact pressure of 60 N/mm<sup>2</sup> as well as a constant sliding speed of 15 mm/s. (For the PTFE tests according to EN 1337-2, a contact pressure of 30 N/mm<sup>2</sup> and a sliding speed of 2 mm/s have to be applied.) As it is standard in PTFE tests, the coefficients of friction of MSM® were determined as a function of temperature and at a contact pressure of 30 N/mm<sup>2</sup> as well as a sliding speed of 0.4 mm/s. Figure A also shows that MSM® is also suitable for constant low temperatures. Even at temperatures of -50°C, the friction values are smaller compared to the friction values of PTFE at -35°C. In contrast, PTFE is not suited for a long term use at low temperatures.

**Figure B**

Tested were MSM®-strips with initial lubrication. The tests were conducted in analogy to A, with higher contact pressures and higher sliding velocities to be applied for MSM® compared to PTFE. Due to the fact that the guides reach lower accumulated sliding displacements, MSM® was exposed to only a fifth of the earlier accumulated sliding displacement of 50 km: after 10 km, the coefficient of friction of MSM® still is below the relevant coefficient of friction of PTFE after 2 km. As well, MSM® shows its suitability for temperatures down to -50°C.

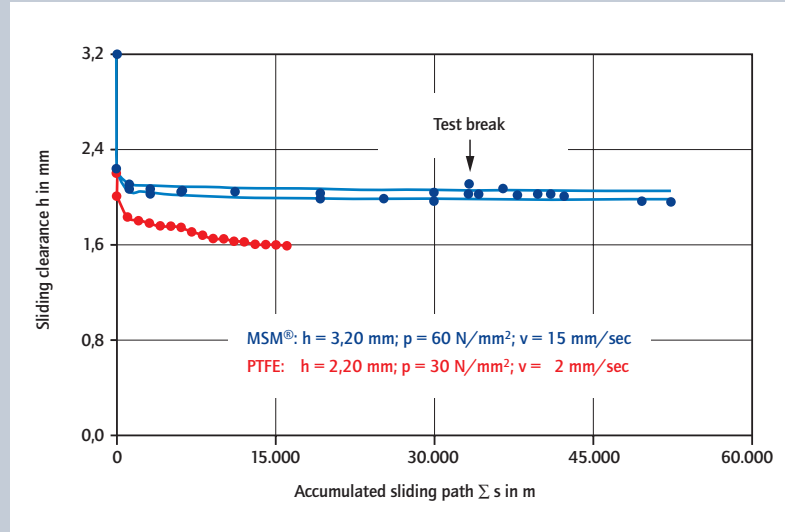
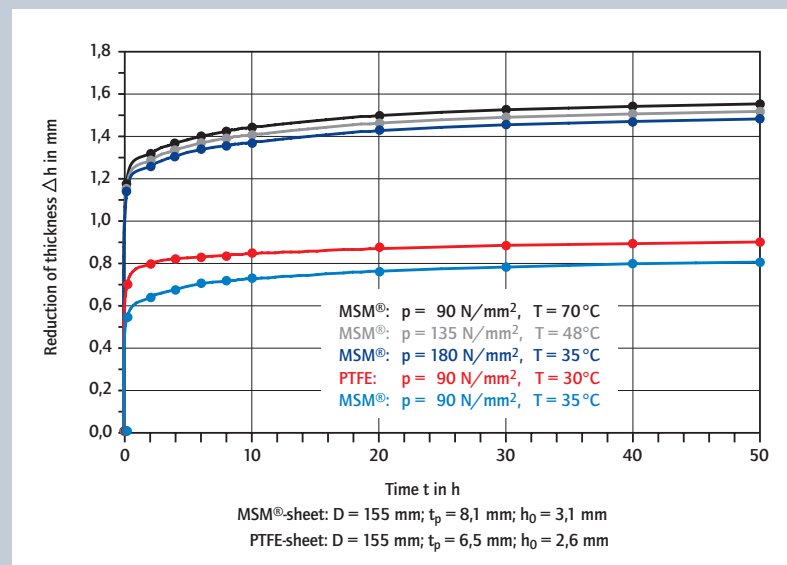

**Figure C: Wear in the same long term test as in Figure A**

**Figure C**

The figure displays the decrease of the sliding clearance at the described long term test. It can clearly be seen that with the exception of the initial elasto-plastic deformation, the sliding clearance almost does not decrease further over the total sliding displacement. The decrease

of the sliding clearance can be owed to the deformation of lubrication dimples and the formation of a bulbous protrusion at the edge of the sliding material. However, the stable graph shows that MSM® is not subject to wear.



**Figure D: Statical long term deformation test with constant contact pressure**

**Figure D**

The statical load tests, executed at an effective bearing temperature of 35°C, show an initial elasto-plastic deformation as a function of contact pressure, to be followed by a long term creep that subsides after app. 48 hours even under the characteristic contact pressure of 180 N/mm<sup>2</sup> (dark blue graph). Increasing bearing temperatures lead to a reduced load bearing capacity – the grey graph shows the time-strain dependency at 135 N/mm<sup>2</sup> and

48°C, the black graph at 90 N/mm<sup>2</sup> and 70°C. PTFE shows a similar long term behaviour at a contact pressure of 90 N/mm<sup>2</sup> (red graph) and 30°C as well as at 67 N/mm<sup>2</sup> and 48°C. Exposed to the same contact pressure, the deformation behaviour of MSM® and PTFE is similar. That is, in using MSM®, the balancing bedding behaviour known from PTFE can be obtained (light blue graph and red graph in comparison).

# Design and Construction

On behalf of the European Organisation for Technical Approvals (EOTA), the German Institute for Civil Engineering (DIBt) issued the European Technical Approval (ETA 06/0131) for MAURER MSM® Spherical Bearings. The certification to allow the affixing of the CE marking was carried out by the Quality Assurance Association for Structural Steelwork. The manufacturing of MAURER MSM® Spherical Bearings is externally supervised by the MPA Stuttgart. The European Technical Approval is based on the requirements of the European Code EN 1337 – structural bearings.



In the European Technical Approval, the suitability of MSM® is highlighted as follows: "... but especially for non-rigid structures with relatively large and frequent displacements caused by variable loads, next for superstructures that induce fast sliding displacements in the bearings, e.g. in bridges for the high speed railways, as well as for regions with continuously low temperatures". MSM® is patented. The required detailed information is deposited with the DIBt and with the MPA Stuttgart.

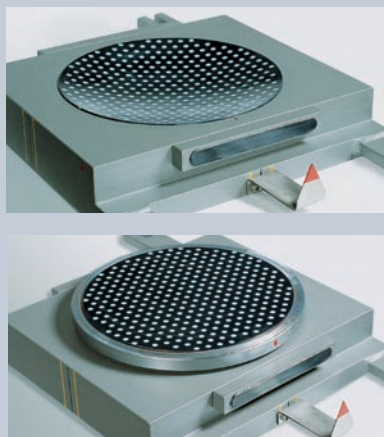

MAURER MSM® Spherical Bearing with guides: concave lower part (above) and with inserted calotte (below).

# Permissible Contact Pressures

Charact. permissible pressure $f_c$ in $N/mm^2$ [ $T \leq 35^\circ C$ ]	Main sliding surface constant and variable loads	180
	Guides variable loads	180
	Guides constant loads, loads from temperature, creep and shrinkage	60
Partial safety coefficient $\gamma_m$ acc. to EN 1990		1,4

Characteristic values of the permissible contact pressures of MSM®

The characteristic values of the permissible contact pressure of MSM® are the double values compared to PTFE, and for constant loads in the horizontal guidings even the 6 fold values. The coefficients of friction of MSM®-sheets with dimples as a function of the contact pressure can be calculated, depending on the temperature region, according to the following formulas [PTFE-values in brackets].

$$T \geq -50^\circ C: 0,027 \leq \mu_{max} = \frac{2,8}{30 + p} \leq 0,08$$

$$T \geq -35^\circ C: 0,020 \leq \mu_{max} = \frac{1,6}{15 + p} \leq 0,08$$

$$[0,030 \leq \mu_{max} = \frac{1,2}{10 + p} \leq 0,08]$$

$$T \geq -5^\circ C: 0,015 \leq \mu_{max} = \frac{1,2}{15 + p} \leq 0,06$$

$$[0,020 \leq \mu_{max} = \frac{0,8}{10 + p} \leq 0,06]$$

It must be emphasized that the coefficients of friction were taken at the extremely high sliding speed of 15 mm/s, and also considering the enormous accumulated sliding path of 50 km. For MSM®-strips with initial lubrication in guides, the coefficients of friction were formulated depending on the temperature region but independently from the occurring pressure values as follows:

$$T \geq -50^\circ C \quad \mu = 12\%$$

$$T \geq -35^\circ C \quad \mu = 10\%$$

$$T \geq -5^\circ C \quad \mu = 7\%$$

Also these coefficients of friction hold for the extreme sliding velocity of 15 mm/s, an accumulated sliding path of 10 km and frequent low temperatures of  $-10^\circ C$ . For PTFE, the regulations formulate a coefficient of friction of 8%. However, as Figure B shows, this value only holds for sliding displacements of 2 km, a sliding velocity of 2 mm/s and temperatures above  $-35^\circ C$ . At these conditions, the relevant MSM®-value remains below 5%.

Figure E: Coefficients of friction of MSM®-sheets with dimples as a function of contact pressure

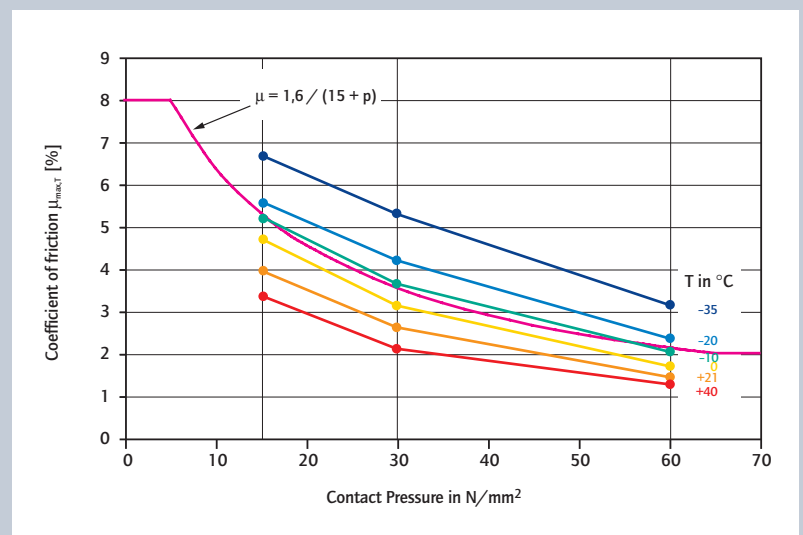

# Bearing Dimensions

Due to the high design contact pressure of MSM®, bridge bearings can be designed in a compact way and thus economical in particular when spherical bearings can be employed and the adjacent structural members can transfer the high contact pressure. This is usually the case with steel superstructures and high strength concrete. In using intermediate elements like steel plates, high strength grouting or basements as well as by means of special reinforcements, this effect can also be achieved with concretes of lower grade. This way, the proof of partial area pressure as requested in DIN report 102:2003 has to be conducted according to the following formula.

$$F_{Rdu} = A_{co} \times f_{cd} \times \sqrt{\frac{A_{c1}}{A_{c0}}} \leq 3,0 \times A_{co} \times f_{cd}$$

$$f_{cd} = \alpha \times f_{ck} \times \frac{f_{ck}}{\gamma_c} = 0,85 \times \frac{f_{ck}}{1,5}$$

(for the basic combination of actions and under long term impact)

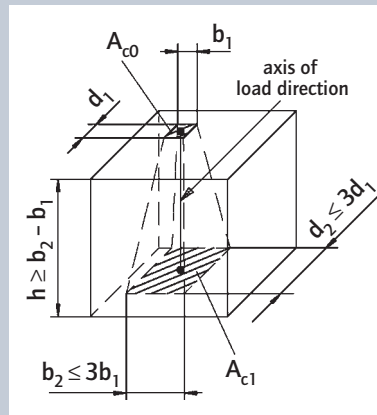
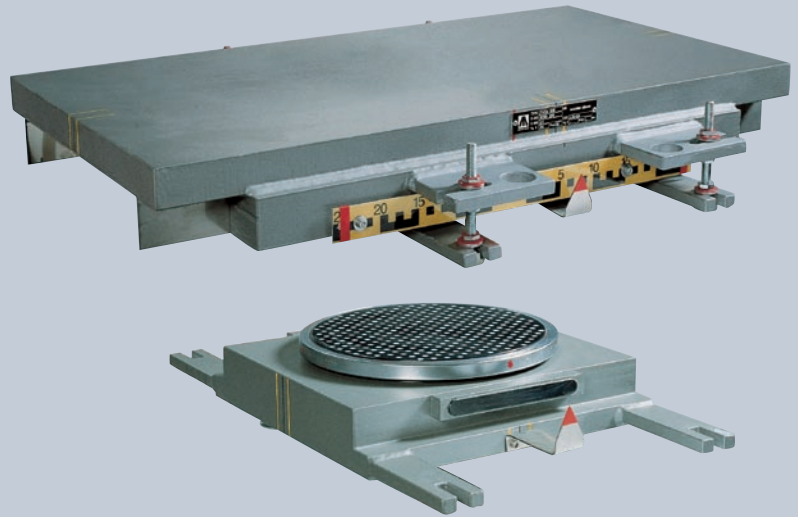

Distribution of the pressure, to serve the proof of partial area pressure

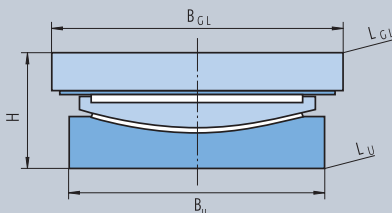

The following tables reflect the guide values for the main dimensions of MAURER MSM® Spherical Bearings as a function of the relevant concrete grade.

Assumptions:  
 $\tan \varphi \leq 0,01$   
 $e_y = \pm 10 \text{ mm}$

Concrete grade C35/45											
MSM® Bearing Type	Load V* kN	H mm	B <sub>u</sub> mm	L <sub>u</sub> mm	B <sub>GL</sub> mm	ex = 50 mm		ex = 100 mm		ex = 150 mm	
						L <sub>GL</sub> mm	Weight kg	L <sub>GL</sub> mm	Weight kg	L <sub>GL</sub> mm	Weight kg
KGa - 1	1000	110	170	200	310	35	420	45	530	55	
KGa - 5	5000	115	330	360	470	110	580	125	690	140	
KGa - 10	10000	130	450	480	590	210	700	230	810	250	
KGa - 25	25000	170	690	730	840	650	950	690	1060	730	
KGa - 50	50000	290	990	1020	1130	2200	1240	2300	1350	2400	

Concrete grade C40/50											
MSM® Bearing Type	Load V* kN	H mm	B <sub>u</sub> mm	L <sub>u</sub> mm	B <sub>GL</sub> mm	ex = 50 mm		ex = 100 mm		ex = 150 mm	
						L <sub>GL</sub> mm	Weight kg	L <sub>GL</sub> mm	Weight kg	L <sub>GL</sub> mm	Weight kg
KGa - 1	1000	110	170	200	310	35	420	45	530	55	
KGa - 5	5000	115	320	350	460	100	570	115	680	125	
KGa - 10	10000	130	440	470	580	200	690	220	800	240	
KGa - 25	25000	165	670	700	810	600	920	640	1030	680	
KGa - 50	50000	280	960	990	1100	2050	1210	2150	1320	2250	

\* Design value of the fundamental combination of actions acc. to EN 1990

# MAURER MSM® Sliding Bearings

Photograph under friendly approval by Transrapid International



Transrapid-project:  
Airport Munich to  
Centre

**MSM®** is a new developed, innovative sliding material. In bridge structures, **MAURER MSM® Sliding Bearings** outperform conventional PTFE bearings, employing at least the following features:

- Facilitates 7.5-fold speed
- Twice the load capacity
- 5-fold increase in total sliding distances
- Coefficient of friction less than 3 %, even at temperatures down to -50 °C

This all adds up to at least a **40-fold increase in service life**, **smaller dimensions** and a **more economical construction**.



**Low Friction.**



**High Speed Motions.**



**Long Life.**



**High Pressure.**



**Maurer Söhne Head Office**  
Frankfurter Ring 193, 80807 Munich/Germany  
P. O. Box 44 01 45, 80750 Munich/Germany  
Phone +49/89/3 23 94-0  
Fax +49/89/3 23 94-3 06  
ba@maurer-soehne.de  
www.maurer-soehne.de

**Maurer Söhne Main Branch Office**  
Zum Holzplatz 2, 44536 Lünen/Germany  
P. O. Box 63 40, 44520 Lünen/Germany  
Phone +49/2 31/4 34 01-0  
Fax +49/2 31/4 34 01-11

**Maurer Söhne Subsidiary Plant**  
Kamenzer Str. 4-6, 02992 Bernsdorf/Germany  
P. O. Box 55, 02992 Bernsdorf/Germany  
Phone +49/3 57 23/2 37-0  
Fax +49/3 57 23/2 37-20